

Solid OR 50 Scale 1:5

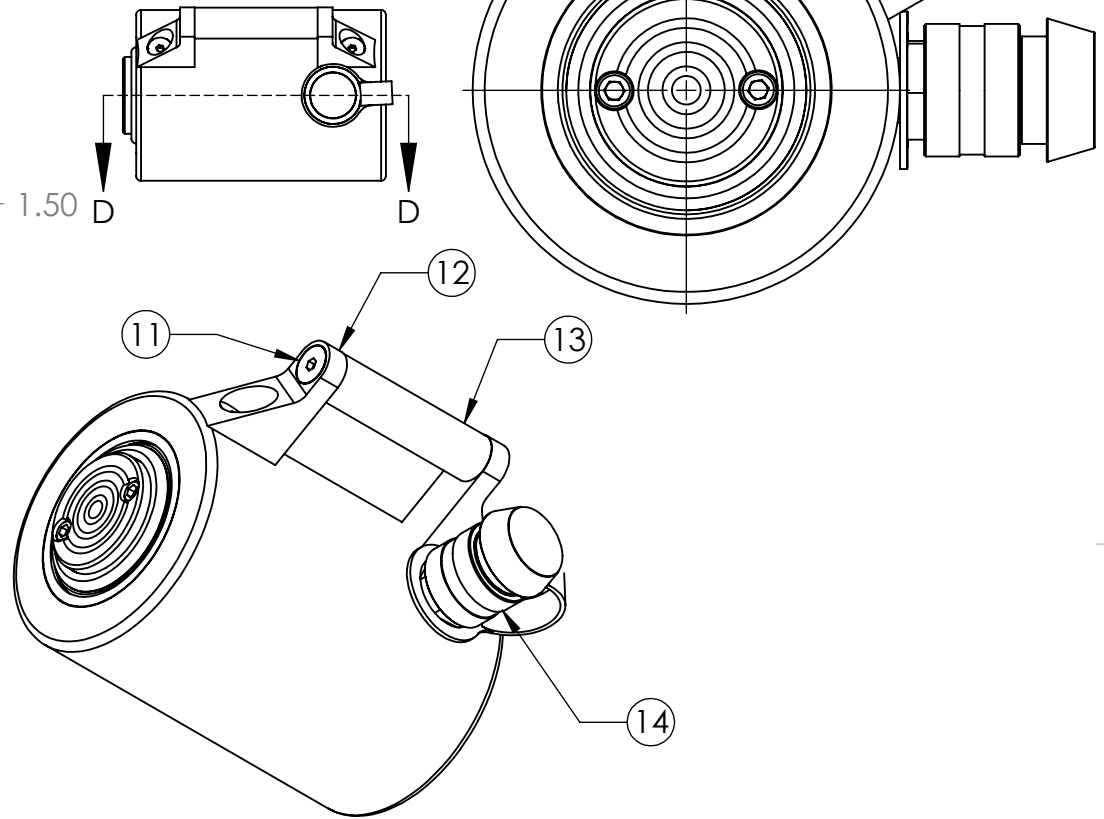

Solid OR 50 3D Scale 1:3

Note: # = stroke

| ITEM NO. | QTY. | PART DISCRIPTION | PART CODE |
|----------|------|------------------------------|-------------|
| 1 | 1 | SADDLE | OR50 -1 |
| 2 | 1 | WIPER RING | OR50 -2 |
| 3 | 1 | RETAINING NUT | OR50 - 3 |
| 4 | 1 | PISTON | OR50/#-4 |
| 5 | 1 | PISTON SEALS | OR50 -5 |
| 6 | 1 | SPRING ASSEMBLY | OR50/#-6 |
| 7 | 1 | CYLINDER HOUSING | OR50/#-7 |
| 8 | 2 | COPPER GASKET | OR50 - 8 |
| 9 | 2 | CAP SCREW | OR50 - 9 |
| 10 | 2 | SADDLE SCREWS | OR50 - 10 |
| 11 | 4 | ALLAN HEAD COUNTERSUNK SCREW | 516NC34 |
| 12 | 2 | HANDLE SUPPORT | HND01 |
| 13 | 1 | HANDLE BAR | OR50/# - 13 |
| 14 | 1 | COUPLER & DUST CAP | FQCDC01 |
| 15 | | 50 TON SEAL KIT (2,5,8) | ORS 50 |

DO NOT SCALE DRAWING

REVISION AUGUST 2013

ORBIT MANUFACTURING INC.

TITLE:

Assembly

Orbit Manufacturing Inc.
#104 - 3070 Norland Avenue
Burnaby, B.C.
Canada V5B 3A6

DWG NO.

OR 50

Letter

SCALE:1:5

SHEET 1 OF 1