

SECTION A-A  
SCALE 1 : 3

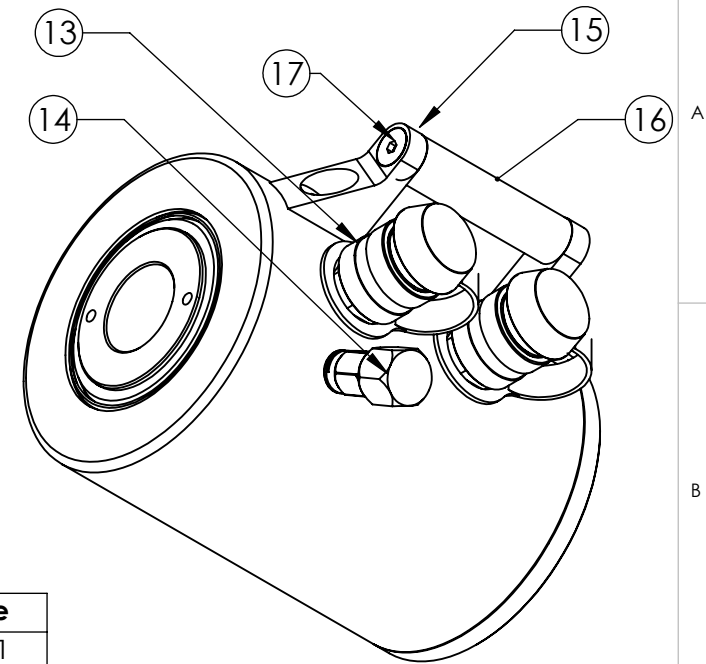
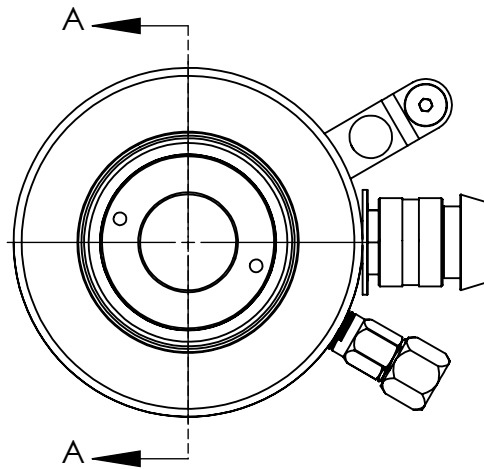

Item	QTY.	Part Description	Part Code
1	1	Cylinder Wiper	ORDH30-1
2	1	Cylinder Polypack	ORDH30-2
3	1	Cylinder Body	ORDH30/#-3
4	1	Piston	ORDH30/#-4
5	1	Inner Tube	ORDH30/#-5
6	1	Piston Wiper	ORDH30-6
7	1	Polypack (Inner pist)	ORDH30-7
8	1	Piston Seal	ORDH30-8
9	1	Polypack (Inner nut)	ORDH30-9
10	1	Polypack (Outer Nut)	ORDH30-10
11	1	Bottom Nut	ORDH30-11
12	1	Saddle	ORDH30-12
13	2	Coupler & Dust Cap	FQCDC01
14	1	Relief Valve	RELVA01
15	2	Handle Support	HND01
16	1	Handle Bar	ORDH30/#-16
17	4	Handle Screw	HNDSC01
18	1	Steel Base Plate (opt.)	SBPORDH30
19	6	Base Plate Screw (opt.)	516NC34
20	1	Seal Kit (1,2,6,7,8,9,10)	ORDHS30

NOTE: # = Stroke

DO NOT SCALE DRAWING

REVISION AUGUST 2013

ORBIT MANUFACTURING INC.

TITLE:

ORDH 30 Assembly

DWG NO.

ORDH 30 / 2,4,6,8,10

LETTER

SCALE:1:5

SHEET 1 OF 1