

SECTION A-A
SCALE 1 : 3

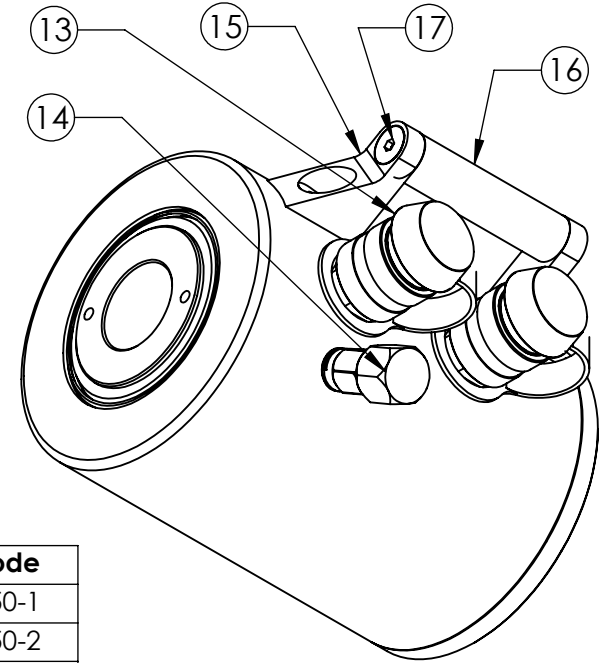
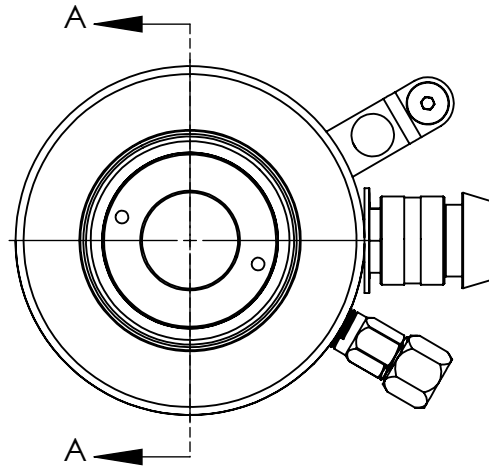

NOTE: # = Stroke

Item	QTY.	Description	Part Code
1	1	Cylinder Wiper	ORDH50-1
2	1	Cylinder Polypack	ORDH50-2
3	1	Cylinder Body	ORDH50/#-3
4	1	Piston	ORDH50/#-4
5	1	Inner Tube	ORDH50/#-5
6	1	Piston Wiper	ORDH50-6
7	1	Polypack (Inner pist)	ORDH50-7
8	1	Piston Seal	ORDH50-8
9	1	Polypack (Inner nut)	ORDH50-9
10	1	Polypack (Outer Nut)	ORDH50-10
11	1	Bottom Nut	ORDH50-11
12	1	Saddle	ORDH50-12
13	2	Coupler & Dust Cap	FQCDC01
14	1	Relief Valve	RELVA01
15	2	Handle Support	HND01
16	1	Handle Bar	ORDH50/#-16
17	4	Handle Screw	HNDSC01
18	1	Steel Base Plate (opt.)	SBPORDH50
19	6	Base Plate Screw (opt.)	516NC34
20	1	Seal Kit (1,2,6,7,8,9,10)	ORDHS50

DO NOT SCALE DRAWING

REVISION AUGUST 2013

ORBIT MANUFACTURING INC.

TITLE:

ORDH 50 Assembly

DWG NO.

ORDH 50 / 2,4,6,8,10

A4

SCALE:1:5

SHEET 1 OF 1